

**Part Number: PU060-12114-P1
PU060-12115-P1**

Kit Contents

Item #	Quantity Req'd.	Description
1	1	Front Passenger Side Splashguard
2	1	Front Driver Side Splashguard
3	1	Rear Passenger Side Splashguard
4	1	Rear Driver Side Splashguard
5	1	Hardware Kit
6	1	Instruction Sheet (Electronic Copy)

Hardware Bag Contents

Item #	Quantity Req'd.	Description
1	2	M5 x 20 mm Screws
2	4	#14 X 19mm Screws
3	6	M5 Spring Clips (small)
4	6	M5 x 15mm Screws
5	4	#14 x 19mm Hex Screws
6	2	M5 Spring Clips (large)

Additional Items Required For Installation

Item #	Quantity Req'd.	Description
1		
2		
3		

Conflicts

Ground effects

Recommended Tools

Personal & Vehicle Protection	Notes
None	
Special Tools	Notes
None	
Installation Tools	Notes
Screwdriver	Phillips #2, #3
Socket & Driver	10mm (3/8")
Clean Cloth/Rag	
Drill	90 ° / 45 °
Drill Bit	6mm (1/4")
Torque Wrench	0-100 ft-lbf
Special Chemicals	Notes
Cleaner	VDC Approved Cleaner

General Applicability

All Models

Recommended Sequence of Application

Item #	Accessory
1	
2	
3	

*Mandatory

Vehicle Service Parts (may be required for reassembly)

Item #	Quantity Req'd.	Description
1		
2		
3		

Legend

 **STOP:** Damage to the vehicle may occur. Do not proceed until process has been complied with.

 **OPERATOR SAFETY:** Use caution to avoid risk of injury.

 **CAUTION:** A process that must be carefully observed in order to reduce the risk of damage to the accessory/vehicle and to ensure a quality installation.

 **TOOLS & EQUIPMENT:** Used in Figures calls out the specific tools and equipment recommended for this process.

 **REVISION MARK:** This mark highlights a change in installation with respect to previous issue.

 **SAFETY TORQUE:** This mark indicates that torque is related to safety.



Care must be taken when installing this accessory to ensure damage does not occur to the vehicle. The installation of this accessory should follow approved guidelines to ensure a quality installation.

These guidelines can be found in the "Accessory Installation Practices" document.

This document covers such items as:-

- Vehicle Protection (use of covers and blankets, cleaning chemicals, etc.).
- Safety (eye protection, rechecking torque procedure, etc.).
- Vehicle Disassembly/Reassembly (panel removal, part storage, etc.).
- Electrical Component Disassembly/Reassembly (battery disconnection, connector removal, etc.).

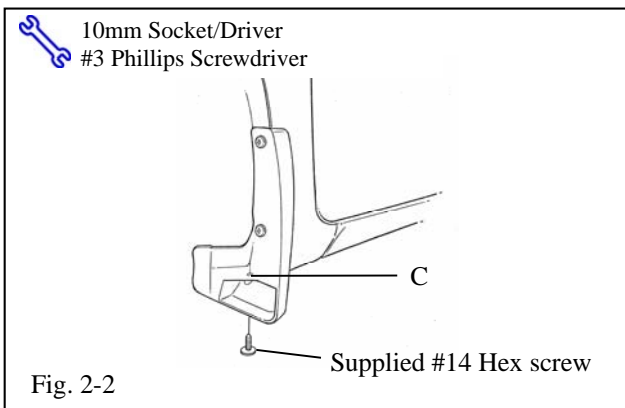
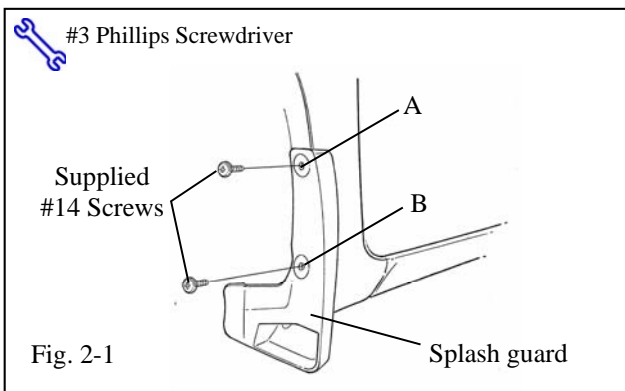
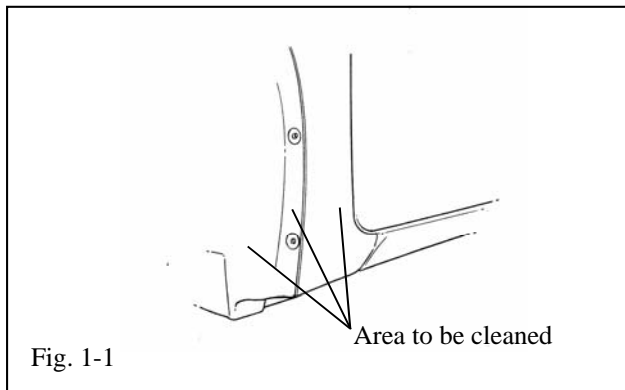

Please see your Toyota dealer for a copy of this document.



1. Clean Front Mounting Area

-  (a) Clean and degrease front body panel where splash guard is to be located with a clean cloth and VDC approved cleaner (Fig. 1-1).

2. Installation of Front Splash Guard

-  (a) Mount splash guard on body panel and install supplied #14 screw in location B while holding part up and into body panel, then tighten (Fig. 2-1).
Do Not Over Tighten.
-  (b) Install supplied #14 screw in location A while holding part up and into body panel, then tighten (Fig. 2-1).
Do Not Over Tighten.
-  (c) Install supplied #14 hex screw in location C while holding part up and into body panel, then tighten (Fig. 2-2).
Do Not Over Tighten.
- (d) Repeat procedure for other side.

3. Clean Rear Mounting Area and Remove Wheel



NOTE: REMOVAL AND REINSTALLATION OF REAR WHEELS IS REQUIRED TO DRILL PANEL EDGE ATTACHMENT HOLES UNLESS A SIDE-ANGLE DRILL IS USED.



(a) Clean and degrease rear bumper panel where splash guard is to be located with a clean cloth and VDC approved cleaner.



(b) If straight and accurate holes cannot be drilled, support the vehicle and remove the rear wheel. Follow the Owner's Manual procedure.

4. Hole Preparation and Clips



(a) Drill 6mm (1/4") holes in panel edge at dimple locations A and B (Fig. 4-1).

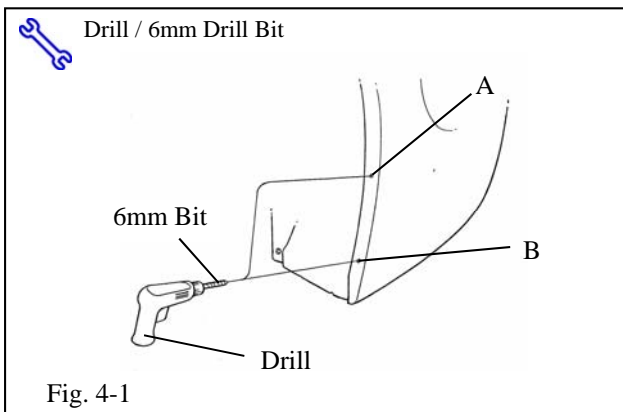



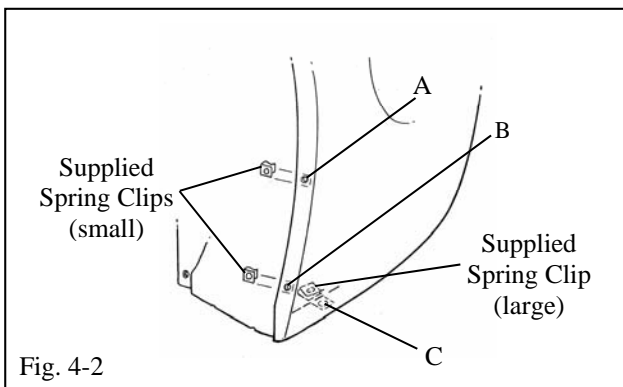

(b) Install supplied spring clips (small) over panel edge holes locations A and B with turned up edge on inside of panel (Fig. 4-2).

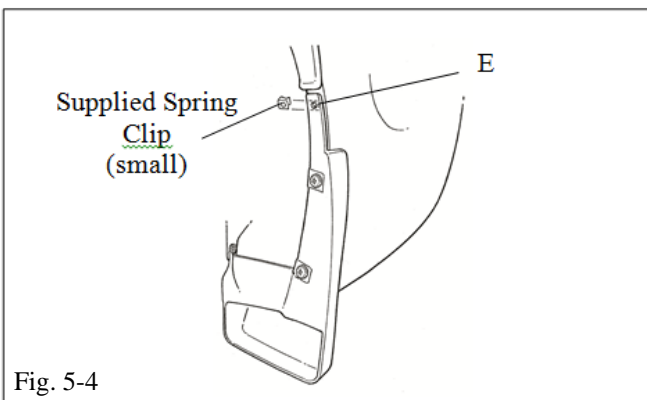
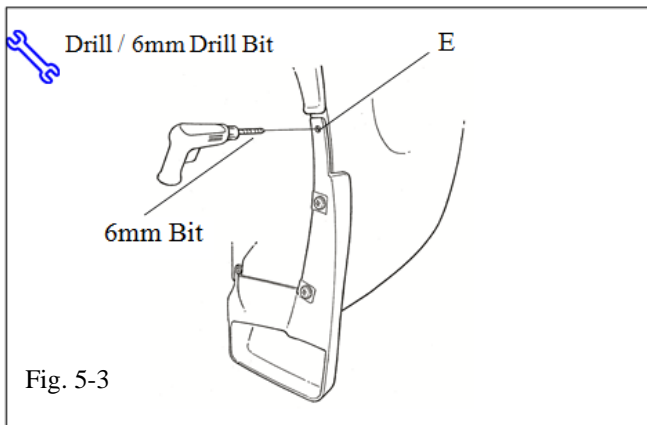
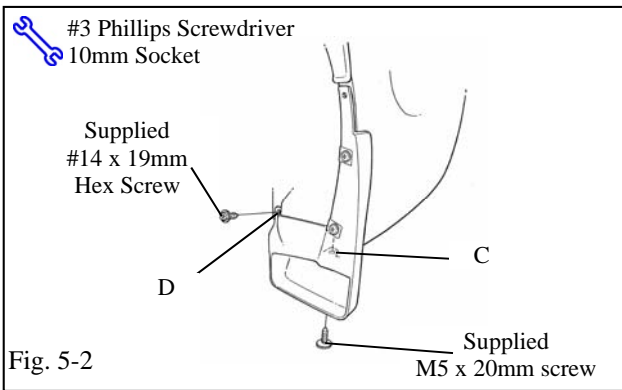
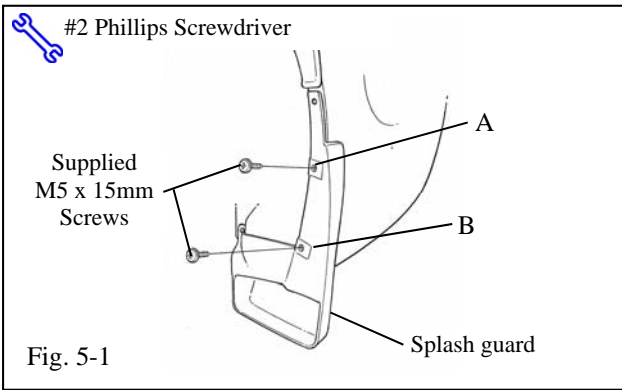

(c) Install supplied spring clip (large) over panel edge hole location C with turned up edge on inside of panel (Fig. 4-2).



5. Installation Of Rear Splash Guard

-  (a) Mount splash guard and install M5 screw 15mm in location B then A while holding part up and into bumper panel and tighten (Fig. 5-1).
-  (b) Install supplied M5 screw 20 mm in location C while holding part up and into bumper panel and tighten (Fig. 5-2).
-  (c) Install supplied #14 hex screw in location D while holding part up and into bumper panel and tighten (Fig. 5-2).
-  (d) Using part as a template hold tight to panel and drill 6mm (1/4 ") hole through panel edge and liner at location E (Fig. 5-3).
-  (e) Install supplied spring clip (small) over panel edge hole with turned up edge on inside of panel and between liner at location E (Fig. 5-4).

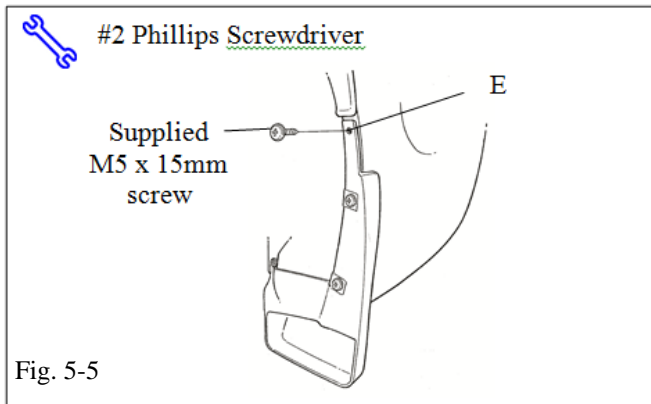

(f) Install supplied M5 screw 15mm in location E and tighten (Fig. 5-5).

(g) If the wheel was removed Step 3 (b), reinstall it now and torque the lug nuts to 103 N·m (76 ft·lbf).



Torque: 103 N·m (76 ft·lbf)

(h) Repeat procedure for other side.

Checklist - these points **MUST** be checked to ensure a quality installation.

Check:

Accessory Function Checks

- Gaps between mudguards and body side
-  Inspect torques

Look For:

Excessive gaps greater than 1.0 mm.

If the wheels were removed, torque the lug nuts to **103 N•m (76 ft•lbf)**.

Vehicle Appearance Check

- After accessory installation and removal of protective cover(s), perform a visual inspection.

Ensure no damage (including scuffs and scratches) was caused during the installation process.

(For PPO installations, refer to TMS Accessory Quality Shipping Standard.)